



aerospace  
climate control  
electromechanical  
filtration  
fluid & gas handling  
hydraulics  
**pneumatics**  
process control  
sealing & shielding



# Air Bellows

Series 9109

Size Ø70 to Ø660 mm (Ø2 3/4" to Ø26")

Catalogue PDE2576TCUK May 2012



ENGINEERING YOUR SUCCESS.

Features	Air cylinder	Hydraulic cylinder	Electro mechanical actuators
Overload safe	***	***	*
Easy to limit force	***	***	*
Easy to vary speed	***	***	*
Speed	***	**	**
Reliability	***	***	***
Robustness	***	***	*
Installation cost	***	*	**
Ease of service	***	**	*
Safety in damp environments	***	***	*
Safety in explosive atmospheres	***	***	*
Safety risk with electrical installations	***	***	*
Risk of oil leak	***	*	***
Clean, hygienic	***	**	*
Standardised measurements	***	***	*
Service life	***	***	*
Hydraulic system required	***	*	***
Weight	**	**	**
Purchase price	***	**	*
Power density	**	***	*
Noise level during operation	**	***	**
High force for size	**	***	*
Positioning possibilities	*	***	***
Total energy consumption	*	**	***
Service interval	*	**	***
Compressor capacity required	*	***	***

\* = good, \*\*=average, \*\*\*=excellent



**Important**  
 Before attempting any external or internal work on the cylinder or any connected components, make sure the cylinder is vented and disconnect the air supply in order to ensure isolation of the air supply.



**Note**  
 All technical data in this catalogue are typical data only.  
 Air quality is essential for maximum cylinder service life (see ISO 8573).



**WARNING**

**FAILURE OR IMPROPER SELECTION OR IMPROPER USE OF THE PRODUCTS AND/OR SYSTEMS DESCRIBED HEREIN OR RELATED ITEMS CAN CAUSE DEATH, PERSONAL INJURY AND PROPERTY DAMAGE.**

This document and other information from Parker Hannifin Corporation, its subsidiaries and authorized distributors provide product and/or system options for further investigation by users having technical expertise. It is important that you analyze all aspects of your application and review the information concerning the product or system in the current product catalog. Due to the variety of operating conditions and applications for these products or systems, the user, through its own analysis and testing, is solely responsible for making the final selection of the products and systems and assuring that all performance, safety and warning requirements of the application are met. The products described herein, including without limitation, product features, specifications, designs, availability and pricing, are subject to change by Parker Hannifin Corporation and its subsidiaries at any time without notice.

**SALE CONDITIONS**

The items described in this document are available for sale by Parker Hannifin Corporation, its subsidiaries or its authorized distributors. Any sale contract entered into by Parker will be governed by the provisions stated in Parker's standard terms and conditions of sale (copy available upon request).

<b>Contents</b>	<b>Page</b>
Air Bellows, general.....	4
Applications.....	5
Developed forces .....	6
Selection of Air Bellows .....	6
Material.....	7
Operation data .....	7
Mounting.....	7
Clamping torques for screws and mounting nuts .....	7
Main data.....	7
Working medium, air quality .....	7
Angular misalignment.....	8
Axial misalignment .....	8
Vibration isolation (damping) charts.....	9
Mounting dimensions .....	10-11
Air Bellows minimum and maximum volume .....	12
Orders codes .....	13
Spare parts.....	14

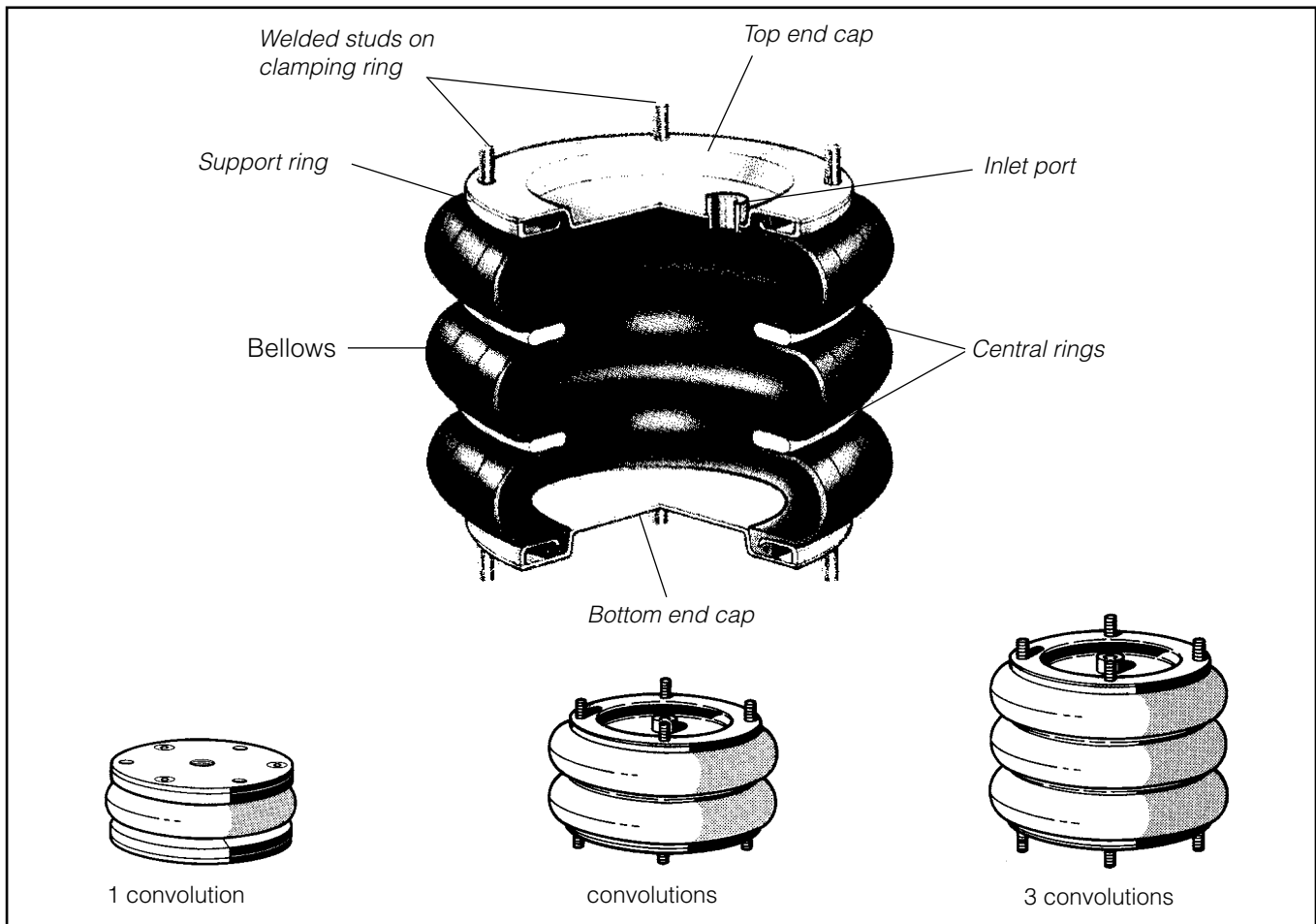

## Air Bellows

Air bellows are the ideal choice for applications requiring short stroke, high thrust single acting actuators.

Manufactured from fabric reinforced synthetic rubber in one, two or three convolutions according to stroke and model. They incorporate no reciprocating metal parts and so provide virtually frictionless thrust compared with conventional pneumatic cylinders.

All models are single acting only. The return stroke is provided in part by the natural spring action of the bellows but more usually by the load itself.

The simplicity of construction provides an extremely long, virtually maintenance-free service life even under arduous conditions.

Air bellows are suitable for vibration applications i.e. device feeders at high frequency.

### Versions

Air bellows are available with aluminium or steel end plates and support rings depending upon type (see page 7).

## Operation

Due to their flexible construction the mounting of Air Bellows is less critical than with conventional pneumatic cylinders, which normally require rigid fixing and guidance and provide only one axis within a limit of 15° between faces. Additionally the axial location of the end plates may be off set by up to 10 mm.

When pressurised Air Bellows will follow the line of least resistance. Accordingly care must be taken with the mounting geometry in angled applications.

When depressurised Air Bellows will fit in to surprisingly small spaces, especially useful for clamping or moving awkwardly shaped or very heavy loads.

In operation it is recommended that the unit is not allowed to "bottom out" or achieve its maximum height. Various mechanical devices may be employed to achieve this.

Applications

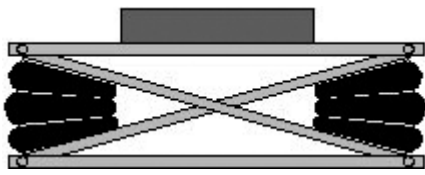

Scissor lift

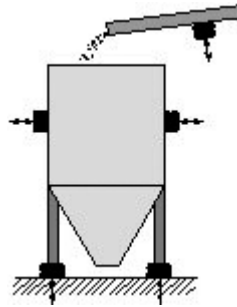

Hopper vibration and damping



Mechanical handling stop



Quick lock device

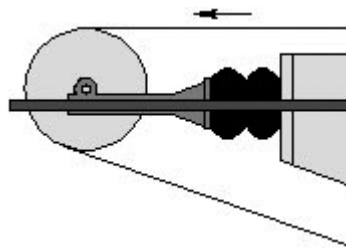

Reel tensioning

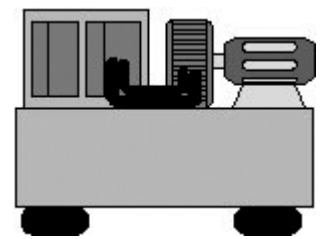

Machine isolation

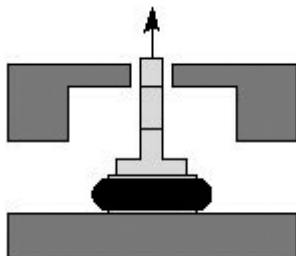

Direct force

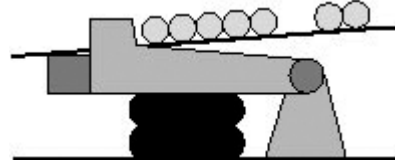

Impact absorption

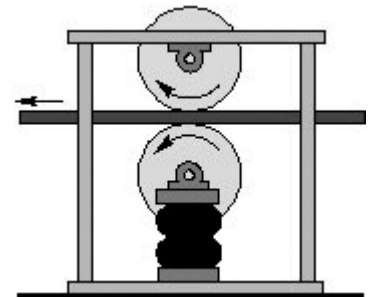

Roller tensioning



Platform lift

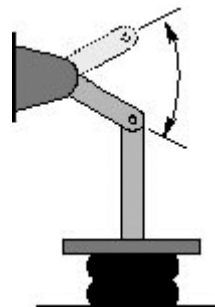

Short stroke mechanical linkage

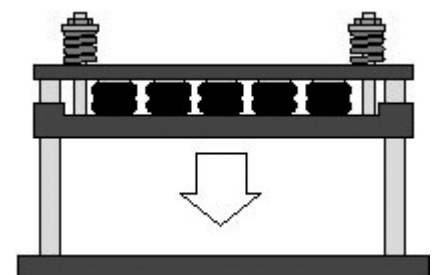

Hot foil stamping press

**Developed forces**

Types bore mm inch	Max force in N for max stroke at 1 bar	Max stroke mm	Height mm		Load to obtain min. height in N	Force (in N) at 1 bar Note : Max. force and stroke may exceed values - see columns to the left													
			min	max															
<b>70</b> 2¾	70	50	65	115	140	400	250	70											
	70	65	80	145	140	370	270	150											
<b>110</b> 4½	200	45	45	90	120	1150	700	200											
	280	80	65	145	130	900	750	550	300										
	280	100	100	200	140	900	750	600	450	280									
<b>150</b> 6	350	55	50	105	140	1900	1200	500											
	400	112	78	190	170	1800	1650	1400	1100	800	450								
	400	173	102	275	190	1800	1600	1400	1200	1000	800	600	400						
<b>200</b> 8	850	75	50	125	120	3200	2400	1700	850										
	800	180	70	250	130	3000	2900	2600	2250	1900	1600	1200	800						
	800	225	100	325	150	3000	27500	2500	2250	2000	1750	1500	1250	1050	950				
<b>250</b> 10	1000	100	50	150	100	5000	4000	3300	2100	1000									
	1250	200	70	270	100	4800	4500	4250	3700	3200	2800	2400	1800	1250					
	800	300	100	400	110	4800	4600	4400	4160	3900	3600	3300	2900	2500	2100	1700	1300	800	
<b>300</b> 12	2000	100	50	150	90	6500	5900	4900	3500	2000									
	2250	195	75	270	90	6800	6400	6000	5200	4800	4200	3150	2950	2250					
	1800	330	100	430	100	6800	6500	6200	5850	5500	5200	4800	4400	4000	3600	3000	2500	1800	
<b>370</b> 14½	3500	115	50	165	80	9600	8800	7700	6300	4500									
	4500	225	70	295	80	10000	9500	9000	8500	7800	7250	6600	6000	5250	4500				
	3500	350	100	450	290	10200	10000	9700	9550	9250	8750	8500	8000	7500	7100	6500	6000	5500	
<b>410</b> 16	5300	250	75	325	80	11400	11100	10600	10100	9600	9000	8400	7750	7200	6500	5300			
	4200	375	125	500	640	10500	10250	10000	9600	9250	8900	8600	8200	7700	7250	6750	6250	5750	
<b>550</b> 21½	6000	300	90	390	70	24000	23000	22000	20080	19500	18200	17000	15300	13800	12000	10000	8000	6000	
<b>660</b> 26	18200	310	90	400	70	30800	30500	30000	29200	28100	26900	25600	24300	23000	21800	20700	19500	18200	
<b>Stroke</b>						<b>0</b>	<b>25</b>	<b>50</b>	<b>75</b>	<b>100</b>	<b>125</b>	<b>150</b>	<b>175</b>	<b>200</b>	<b>225</b>	<b>250</b>	<b>275</b>	<b>300</b>	

**Colour codes for air bellow types**

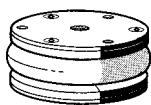

One convolution

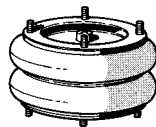

Two convolutions

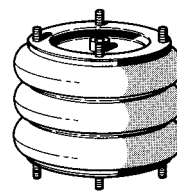

Three convolutions

**Selection of Air Bellows**

1. Establish the force required in N at working air pressure.
2. Divide the force required by the working air pressure in bar.
3. Select the standard stroke: always choose the next highest stroke to that required.
4. Read upwards in the column to find the figure equal to or greater than the figure which resulted from step 2.
5. Read across to the left for recommended unit size.

**Example**

1. Force required 35000 N. Working air pressure 7 bar.
2. Force at 1 bar is: 35000 / 7 = 5000 N.
3. Stroke required 120 mm - Use 125 mm.
4. Use 125 stroke column, 5200 N at 1 bar.
5. Recommended unit is Ø300 mm (i.e. 12") 3 convolutions.

## Material

### Standard version

#### End plates

Ø 70, 110, 150\*, 550 Aluminium  
(i.e. 2¾", 4½", 6", 21½")

Ø 150\*, 200, 250, 300, 370, 410, 660 Steel  
(i.e. 6", 8", 10", 12", 14½", 16", 26")

#### Clamping ring, central ring

Ø 70, 110, 150\*, 550, 660 Aluminium  
(i.e. 2¾", 4½", 6", 21½", 26")

Ø 150\*, 200, 250, 300, 370, 410 Steel  
(i.e. 6", 8", 10", 12", 14½", 16")

\* Ø 150 (i.e. 6") exists in aluminium and steel version

### Steel 304 version (on studs version):

from Ø 150 to Ø 410 (i.e. from 6" to 16")

## Bellows

### Standard

Natural rubber (NR) (50%), Nitrile butadiene rubber (NBR) (25%), Styrene butadiene rubber (SBR) (25%)

### High temperature version:

Bellows material : Chlorobutyl

## Operation data

Working pressure Max. 8 bar  
Working temperature -30 °C to +70 °C (in dynamic)  
-40 °C to +90 °C (in static)

### High temperature version:

- 30 °C to + 90 °C dynamic  
- 25 °C to + 100 °C static

## Mounting

Ø 70, 110, 150, 550, 660 Threaded holes  
(i.e. 2¾", 4½", 6", 21½", 26")

Ø 150, 200, 250, 300, 370, 410 Studs  
(i.e. 6", 8", 10", 12", 14½", 16")

## Clamping torques for screws and mounting nuts

Ø 70 x 2 and 70 x 3 5 Nm  
(i.e. 2¾" x 2 and 2¾" x 3)

Ø 110 x 1 to 110 x 3 7 up to 11 Nm  
(i.e. 4½" x 1 to 4½" x 3)

Ø 150 x 1 to 150 x 3 12 Nm  
(i.e. 6" x 1 to 6" x 3)

Ø 200 x 1 to 660 x 2 20 to 28 Nm  
(i.e. 8" x 1 to 26" x 2)

## Main data

- 10 sizes, diameters 70-660 mm (i.e. 2¾"-26")
- Strokes from 65 to 430 mm
- Single, double or triple convolutions
- Angular misalignment: 15° max.
- Axial misalignment: 10 mm max.
- High thrust and frictionless movement
- Maintenance free

## Working medium, air quality

Working medium Dry, filtered compressed air  
to ISO 8573-1 class 3.4.3.

### Recommended air quality for cylinders

For best possible service life and trouble-free operation, ISO 8573-1 quality class 3.4.3 should be used. This means 5 µm filter (standard filter) dew point +3 °C for indoor operation (a lower dew point should be selected for outdoor operation) and oil concentration 1.0 mg oil/m<sup>3</sup>, which is what a standard compressor with a standard filter gives.

### ISO 8573-1 quality classes

Quality class	Pollution particle size (µm)	max concentration (mg/m <sup>3</sup> )	Water max. press. dew point (°C)	Oil max concentration (mg/m <sup>3</sup> )
1	0,1	0,1	-70	0,01
2	1	1	-40	0,1
3	5	5	-20	1,0
4	15	8	+3	5,0
5	40	10	+7	25
6	-	-	+10	-

## Angular misalignment

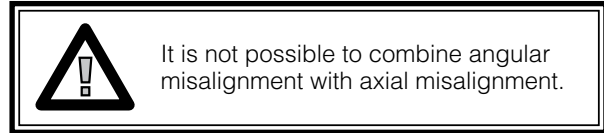
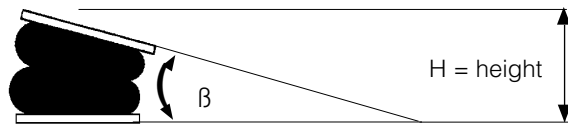

Ø (mm)	Types	Angle β = 5°	Angle β = 10°	Angle β = 15°
		For heights (mm) between	For heights (mm) between	For heights (mm) between
70	2¾ x 2	75-100	80-95	/
	2¾ x 3	90-120	95-110	/
110	4½ x 1	60-75	65-70	/
	4½ x 2	/	80-125	105-145
150	4½ x 3	125-180	130-170	/
	6 x 1	65-90	70-85	/
	6 x 2	/	95-160	100-155
200	6 x 3	195-255	200-250	/
	8 x 1	60-105	70-100	/
	8 x 2	/	90-210	100-205
250	8 x 3	/	250-305	255-300
	10 x 1	/	70-115	80-105
	10 x 2	/	95-260	115-250
300	10 x 3	/	245-370	280-350
	12 x 1	/	75-115	90-105
	12 x 2	/	100-255	110-245
370	12 x 3	/	230-340	250-310
	14 ½ x 1	65-145	85-135	/
	14 ½ x 2	/	115-290	135-275
410	14 ½ x 3	/	300-390	310-370
	16 x 2	/	125-325	135-315
550	16 x 3	/	350-480	370-450
660	21 ½ x 2			
	26 x 2			

## Axial misalignment

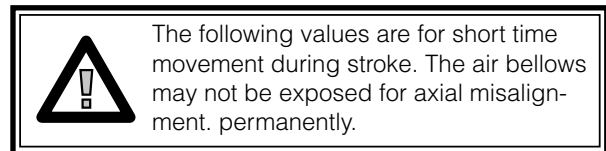
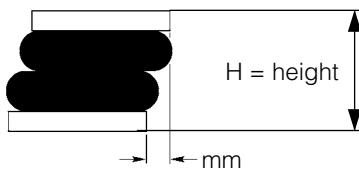

Ø (mm)	Types	5 m m	10 m m
		For heights (mm) between	For heights (mm) between
70	2¾ x 2	80-100	85-95
	2¾ x 3	90-125	100-115
110	4½ x 1	60-80	70-90
	4½ x 2	75-145	85-135
150	4½ x 3	120-200	110-180
	6 x 1	65-95	75-85
	6 x 2	100-175	110-165
200	6 x 3	115-250	105-230
	8 x 1	70-120	65-115
	8 x 2	85-240	95-230
250	8 x 3	110-280	100-260
	10 x 1	65-145	70-135
	10 x 2	95-270	105-200
300	10 x 3	175-390	165-380
	12 x 1	70-135	80-130
	12 x 2	95-280	105-270
370	12 x 3	140-410	150-400
	14 ½ x 1	105-170	85-160
	14 ½ x 2	110-340	120-330
410	14 ½ x 3	160-440	170-430
	16 x 2	170-325	180-315
550	16 x 3	275-500	290-485
660	21 ½ x 2		
	26 x 2		

**Vibration isolation (damping) charts**

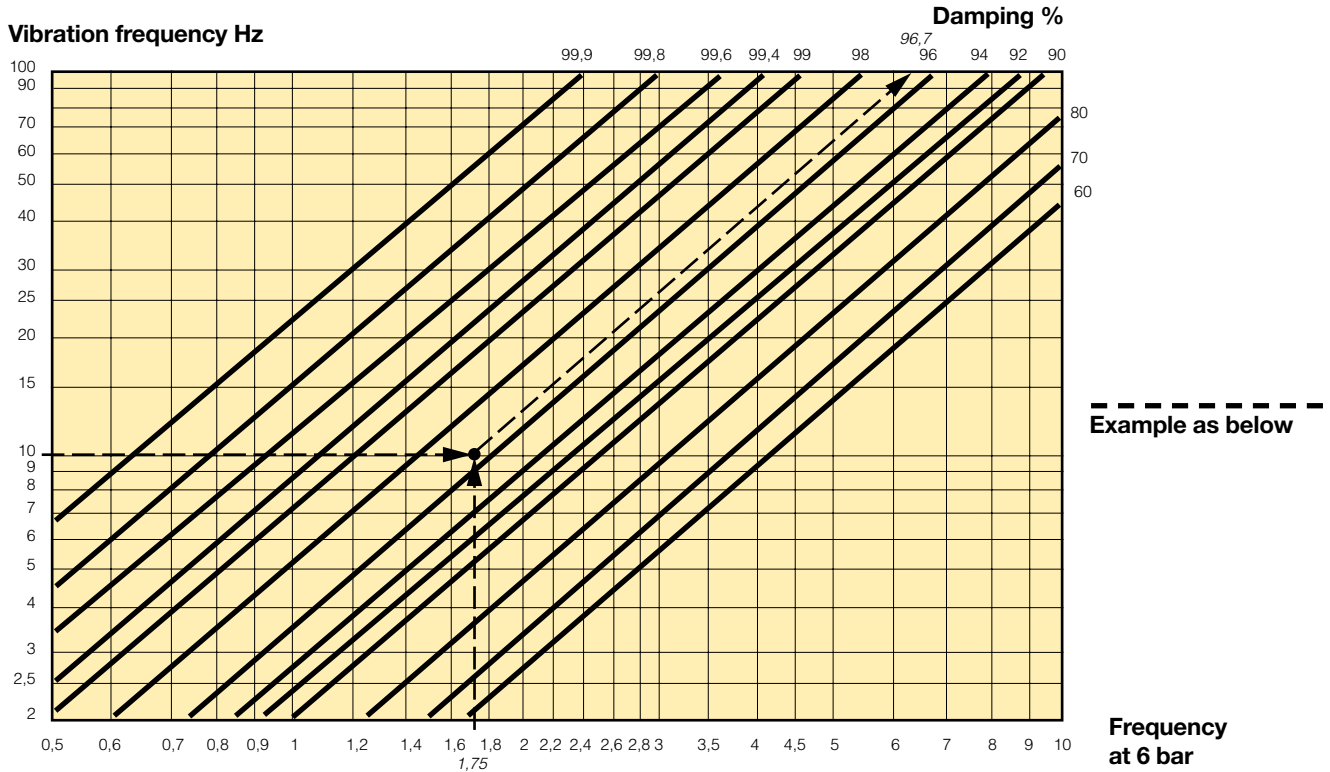

**Air Bellows frequency Hz**

Ø mm	Convolu- tion	Types	Frequency 6 bar Hz	Static height mm	Loading 6 bar in kg
70	2	23/4 X 2	3,8	90	150
	3	23/4 X 3	3,2	110	156
110	1	41/2 X 1	3,8	70	335
	2	41/2 X 2	3	100	390
	3	41/2 X 3	2,6	145	378
150	1	6 X 1	3,2	80	640
	2	6 X 2	2,2	140	685
	3	6 X 3	1,9	180	660
200	1	8 x 1	2,77	90	1275
	2	8 x 2	1,95	160	1225
	3	8 x 3	1,75	210	1200
250	1	10 x 1	2,63	100	1960
	2	10 x 2	1,75	170	1900
	3	10 x 3	1,43	250	1770
300	1	12 x 1	2,44	100	2975
	2	12 x 2	1,78	170	2910
	3	12 x 3	1,44	250	2930
370	1	141/2 x 1	2,22	110	4555
	2	141/2 x 2	1,61	200	4445
	3	141/2 x 3	1,31	290	4320
410	2	16 x 2	1,44	200	5195
	3	16 x 3	1,24	290	4950
550	2	211/2 x 2	1,49	200	11785

**How damping is calculated in %**

1. Search the vertical axis of the graph for the frequency of vibration that requires damping.
2. Search for the loading and size of the unit in the lower table.  
(Note that bellows with twin and triple convolutions give better damping but higher static height.)
3. Having chosen the unit required, select the frequency in Hz on the bottom axis on the graph.
4. Where the lines from steps 1 and 3 intersect, follow the diagonal line up to the top right-hand edge of the graph to find the damping value.

**Example**

1. Frequency to be damped = 10 Hz.
2. Loading of Air Bellows unit = 1500 kg.
3. The bellows cylinder in this example has twin bellows, Ø 250 (10" x 2) which, according to the table, gives a frequency of 1.75 Hz at 6 bar.
4. This produces 96,7% damping according to the diagram above.



Mounting dimensions

Aluminium end plates version  
 $\varnothing 70 \text{ mm } (2\frac{3}{4}'' )$

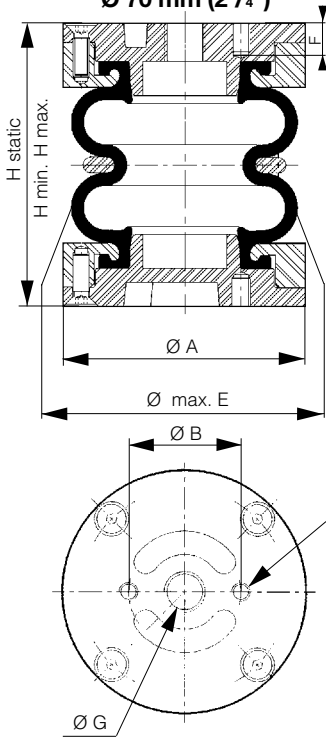

$\varnothing 110 \text{ mm } (4\frac{1}{2}'' )$

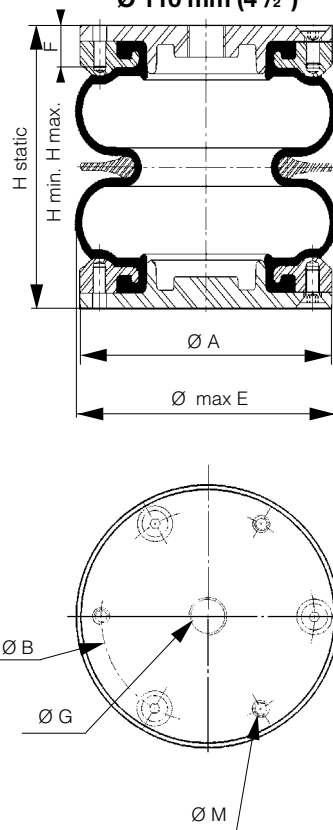

$\varnothing 150 \text{ mm } (6'' )$

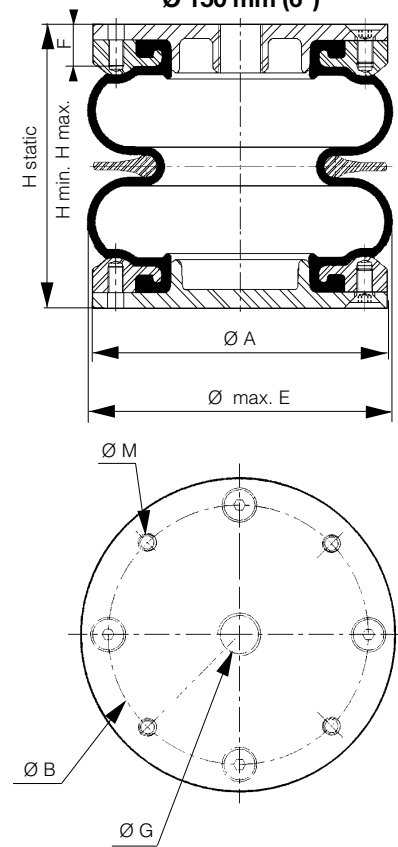

Steel end plates version  
 $\varnothing 150 \text{ to } 410 \text{ mm } (6 \text{ to } 16'' )$

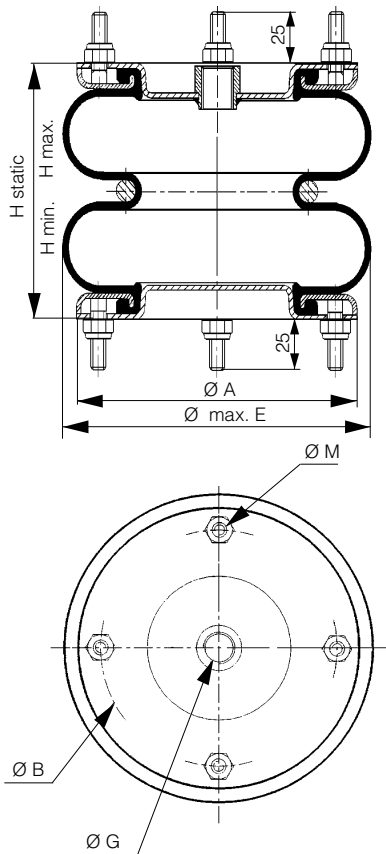

Aluminium end plates version / Steel end plates version  
 $\varnothing 550 \text{ mm } (21\frac{1}{2}'' )$  /  $\varnothing 660 \text{ mm } (26'' )$

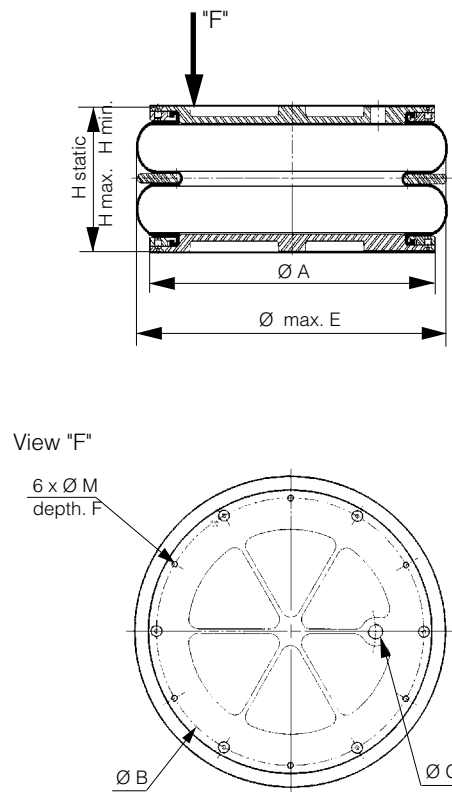

## Mounting dimensions

Ø mm	Types	H min mm	H static mm	H max mm	Max stroke mm	ØE static mm	ØE max mm	ØA mm	ØB mm	F mm	ØM mm	Ø Port size	Max. pressure bar	Weight kg
70	2¾ x 2	65	90	115	50	78	80	78	36	9	M6	G1/4	8	0,5
	2¾ x 3	80	110	145	65	78	80	78	36	9	M6	G1/4	8	0,6
110	4½ x 1	45	65	90	45	114	125	110	93	13	M6	G3/8	8	0,8
	4½ x 2	65	100	145	80	114	125	110	93	13	M6	G3/8	8	1
	4½ x 3	100	145	200	100	114	125	110	93	13	M6	G3/8	8	1,2
150	6 x 1 (alu.)	50	80	105	55	153	175	152,5	127	16	M8	G1/2	8	2
	6 x 1 (steel)	50	80	105	55	153	175	155	127	16	M10	G1/2	8	2,4
	6 x 2 (alu.)	78	130	190	112	153	175	152,5	127	16	M8	G1/2	8	2,7
	6 x 2 (steel)	70	130	190	120	153	175	155	127	16	M10	G1/2	8	2,7
	6 x 3 (alu.)	102	190	275	173	153	175	152,5	127	16	M8	G1/2	8	3
	6 x 3 (steel)	95	190	275	180	153	175	155	127	16	M10	G1/2	8	3
200	8 x 1	50	90	125	75	204	230	184	155,5		M10	G1/2	8	3,05
	8 x 2	70	160	250	180	204	230	184	155,5		M10	G1/2	8	3,75
	8 x 3	100	205	325	225	204	230	184	155,5		M10	G1/2	8	4,3
250	10 x 1	50	100	150	100	254	280	210	181		M10	G1/2	8	3,9
	10 x 2	70	170	270	200	254	280	210	181		M10	G1/2	8	5
	10 x 3	100	250	400	300	254	280	210	181		M10	G1/2	8	5,6
300	12 x 1	50	100	150	100	305	330	260	232		M10	G1/2	8	5,2
	12 x 2	75	170	270	195	305	330	260	232		M10	G1/2	8	6,7
	12 x 3	100	250	430	330	305	330	260	232		M10	G1/2	8	8,1
370	14½ x 1	50	110	165	115	368	395	310	282,5		M10	G1/2	8	6,9
	14½ x 2	70	180	295	225	368	395	310	282,5		M10	G1/2	8	9,1
	14½ x 3	100	280	450	350	368	395	310	282,5		M10	G1/2	8	10
410	16 x 2	75	200	325	250	406	440	310	282,5		M10	G1/2	8	9,7
	16 x 3	125	300	500	375	406	440	310	282,5		M10	G1/2	8	12,5
550	21½ x 2	90	200	390	300	546	580	498,5	470	19	M10	G3/4	7	20,6
	21½ x 2 (Air Bellows less end caps)	90	200	390	300	546	580	498,5	470		M10	G3/4	8	11,5
660	26 x 2	90	200	400	310	660	700	601	470	19	M10	G3/4	8	23



## Clamping torques for screws and mounting nuts

Ø 70 x 2 and 70 x 3 ( i.e. 2¾" x 2 and 2¾" x 3)	5 Nm
Ø 110 x 1 to 110 x 3 ( i.e. 4½" x 1 to 4½" x 3)	7 to 11 Nm
Ø 150 x 1 to 150 x 3 ( i.e. 6" x 1 to 6" x 3)	12 Nm
Ø 200 x 1 to 660 x 2 ( i.e. 8" x 1 to 26" x 2)	20 to 28 Nm



It is imperative that external mechanical stops are used to limit the stroke. The units should not achieve maximum stroke or be allowed to "bottom out".  
Air Bellows may not be stacked, use singly only.

## Air Bellows minimum and maximum volume

Ø	Types	Minimum volume* (at 4 bar) cm <sup>3</sup>	Maximum volume** (at 4 bar) cm <sup>3</sup>
mm			
70	2¾ x 2	75	155
	2¾ x 3	98	206
110	4½ x 1	7	145
	4½ x 2	175	590
	4½ x 3	400	1025
150	6 x 1 (alu.)	70	815
	6 x 1 (steel)	70	815
	6 x 2 (alu.)	120	1670
	6 x 2 (steel)	120	1670
	6 x 3 (alu.)	150	2550
	6 x 3 (steel)	150	2550
200	8 x 1	300	280
	8 x 2	680	4850
	8 x 3	1250	5750
250	10 x 1	400	4400
	10 x 2	1100	8200
	10 x 3	2300	13000
300	12 x 1	793	6400
	12 x 2	500	11900
	12 x 3	8000	21350
370	14½ x 1	910	10700
	14½ x 2	1810	21500
	14½ x 3	4000	33000
410	16 x 2	3610	28300
	16 x 3	9000	39000
550	21½ x 2	10610	55000
660	26 x 2		

\* The minimum volume corresponds to the minimal height of the Air Bellow

\*\* The maximum volume corresponds to the maximal height of the Air Bellow



It is imperative that external mechanical stops are used to limit the stroke. The units should not achieve maximum stroke or be allowed to "bottom out".  
Air Bellows may not be stacked, use singly only.

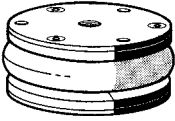
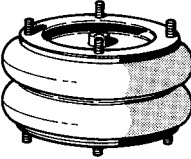
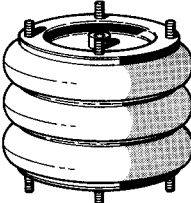

## Orders codes

Symbol	Ø mm	Types	Port size	Max stroke mm	Order code Standard	Order code High temp	Order code Stainless
<b>One convolution</b> 	110	4½ x 1	G3/8	45	9109400	9109600	/
	150	6 x 1 (alu.)	G1/2	55	9109004A	9109204A	/
	150	6 x 1 (steel)	G1/2	55	9109004	9109204	9109004N
	200	8 x 1	G1/2	75	9109014	9109214	9109014N
	250	10 x 1	G1/2	100	9109024	9109224	9109024N
	300	12 x 1	G1/2	100	9109044	9109244	9109044N
	370	14½ x 1	G1/2	115	9109064	9109264	9109064N
<b>Two convolutions</b> 	70	2¾ x 2	G1/4	50	9109009	9109509	/
	110	4½ x 2	G3/8	80	9109401	9109502	/
	150	6 x 2 (alu.)	G1/2	112	9109001A	9109201A	/
	150	6 x 2 (steel)	G1/2	112	9109001	9109201	9109001N
	200	8 x 2	G1/2	180	9109011	9109211	9109011N
	250	10 x 2	G1/2	200	9109021	9109221	9109021N
	300	12 x 2	G1/2	195	9109041	9109241	9109041N
	370	14½ x 2	G1/2	225	9109061	9109261	9109061N
	410	16 x 2	G1/2	250	9109171	9109271	9109171N
	550	21½ x 2 21½ x 2 (Air Bellows less end caps)	G3/4	300	9109150 9109153	9109250 /	/ /
660	26 x 2	G3/4	310	9109156	/	/	
<b>Three convolutions</b> 	70	2¾ x 3	G1/4	65	9109010	9109510	/
	110	4½ x 3	G3/8	100	9109402	9109503	/
	150	6 x 3 (alu.)	G1/2	173	9109007A	9109207A	/
	150	6 x 3 (steel)	G1/2	173	9109007	9109207	9109007N
	200	8 x 3	G1/2	225	9109017	9109219	9109017N
	250	10 x 3	G1/2	300	9109031	9109231	9109031N
	300	12 x 3	G1/2	330	9109051	9109251	9109051N
	370	14½ x 3	G1/2	350	9109069	9109269	9109069N
	410	16 x 3	G1/2	375	9109177	9109275	9109177N

## Spare parts

Ø mm	Types	Bellows		End plates		Support ring	Central ring
		Standard	High temp.	Without inlet port	With inlet port		
<b>One convolution</b>							
110	4½ x 1	9109145	9109288	9109188	9109187	9109186	9109184
150	6 x 1 (alu.)	9109191	9109391	9109070A	9109075A	9109080A	9109098A
	6 x 1 (steel)	9109191	9109391	9109070	9109075	9109080	9109098
200	8 x 1	9109192	9109392	9109071	9109076	9109086	9109099
250	10 x 1	9109146	9109393	9109072	9109077	9109087	9109100
300	12 x 1	9109195	9109395	9109073	9109078	9109088	9109101
370	14½ x 1	9109197	9109397	9109074	9109178	9109089	9109170
<b>Two convolutions</b>							
70	2¾ x 2	9109152	9109303	9109065	9109181	9109193	9109209
110	4½ x 2	9109189	9109289	9109188	9109187	9109186	9109184
150	6 x 2 (alu.)	9109091	9109291	9109070A	9109075A	9109080A	9109098A
	6 x 2 (steel)	9109091	9109291	9109070	9109075	9109080	9109098
200	8 x 2	9109092	9109292	9109071	9109076	9109086	9109099
250	10 x 2	9109093	9109293	9109072	9109077	9109087	9109100
300	12 x 2	9109095	9109295	9109073	9109078	9109088	9109101
370	14½ x 2	9109097	9109297	9109074	9109178	9109089	9109170
410	16 x 2	9109199	9109298	9109074	9109178	9109089	9109170
550	21½ x 2	9109190	9109290	9109068	9109067	9109183	9109185
660	26 x 2	9109198		9109155	9109157	9109183	9109185
<b>Three convolutions</b>							
70	2¾ x 3	9109090	9109304	9109065	9109181	9109193	9109209
110	4½ x 3	9109147	9109287	9109188	9109187	9109186	9109184
150	6 x 3 (alu.)	9109149	9109286	9109070A	9109075A	9109080A	9109098A
	6 x 3 (steel)	9109149	9109286	9109070	9109075	9109080	9109098
200	8 x 3	9109151	9109300	9109071	9109076	9109086	9109099
250	10 x 3	9109094	9109294	9109072	9109077	9109087	9109100
300	12 x 3	9109096	9109296	9109073	9109078	9109088	9109101
370	14½ x 3	9109148	9109301	9109074	9109178	9109089	9109170
410	16 x 3	9109200	9109299	9109074	9109178	9109089	9109170

## Colour codes for air bellow types



One convolution

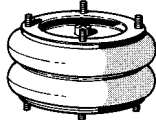

Two convolutions

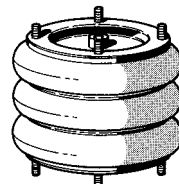

Three convolutions



# Parker Worldwide

## Europe, Middle East, Africa

**AE – United Arab Emirates,** Dubai

Tel: +971 4 8127100  
parker.me@parker.com

**AT – Austria,** Wiener Neustadt

Tel: +43 (0)2622 23501-0  
parker.austria@parker.com

**AT – Eastern Europe,** Wiener Neustadt

Tel: +43 (0)2622 23501 900  
parker.easteurope@parker.com

**AZ – Azerbaijan,** Baku

Tel: +994 50 2233 458  
parker.azerbaijan@parker.com

**BE/LU – Belgium,** Nivelles

Tel: +32 (0)67 280 900  
parker.belgium@parker.com

**BY – Belarus,** Minsk

Tel: +375 17 209 9399  
parker.belarus@parker.com

**CH – Switzerland,** Etoy

Tel: +41 (0)21 821 87 00  
parker.switzerland@parker.com

**CZ – Czech Republic,** Klecany

Tel: +420 284 083 111  
parker.czechrepublic@parker.com

**DE – Germany,** Kaarst

Tel: +49 (0)2131 4016 0  
parker.germany@parker.com

**DK – Denmark,** Ballerup

Tel: +45 43 56 04 00  
parker.denmark@parker.com

**ES – Spain,** Madrid

Tel: +34 902 330 001  
parker.spain@parker.com

**FI – Finland,** Vantaa

Tel: +358 (0)20 753 2500  
parker.finland@parker.com

**FR – France,** Contamine s/Arve

Tel: +33 (0)4 50 25 80 25  
parker.france@parker.com

**GR – Greece,** Athens

Tel: +30 210 933 6450  
parker.greece@parker.com

**HU – Hungary,** Budapest

Tel: +36 1 220 4155  
parker.hungary@parker.com

**IE – Ireland,** Dublin

Tel: +353 (0)1 466 6370  
parker.ireland@parker.com

**IT – Italy,** Corsico (MI)

Tel: +39 02 45 19 21  
parker.italy@parker.com

**KZ – Kazakhstan,** Almaty

Tel: +7 7272 505 800  
parker.easteurope@parker.com

**NL – The Netherlands,** Oldenzaal

Tel: +31 (0)541 585 000  
parker.nl@parker.com

**NO – Norway,** Asker

Tel: +47 66 75 34 00  
parker.norway@parker.com

**PL – Poland,** Warsaw

Tel: +48 (0)22 573 24 00  
parker.poland@parker.com

**PT – Portugal,** Leca da Palmeira

Tel: +351 22 999 7360  
parker.portugal@parker.com

**RO – Romania,** Bucharest

Tel: +40 21 252 1382  
parker.romania@parker.com

**RU – Russia,** Moscow

Tel: +7 495 645-2156  
parker.russia@parker.com

**SE – Sweden,** Spånga

Tel: +46 (0)8 59 79 50 00  
parker.sweden@parker.com

**SK – Slovakia,** Banská Bystrica

Tel: +421 484 162 252  
parker.slovakia@parker.com

**SL – Slovenia,** Novo Mesto

Tel: +386 7 337 6650  
parker.slovenia@parker.com

**TR – Turkey,** Istanbul

Tel: +90 216 4997081  
parker.turkey@parker.com

**UA – Ukraine,** Kiev

Tel: +380 44 494 2731  
parker.ukraine@parker.com

**UK – United Kingdom,** Warwick

Tel: +44 (0)1926 317 878  
parker.uk@parker.com

**ZA – South Africa,** Kempton Park

Tel: +27 (0)11 961 0700  
parker.southafrica@parker.com

## North America

**CA – Canada,** Milton, Ontario

Tel: +1 905 693 3000

**US – USA,** Cleveland

Tel: +1 216 896 3000

## Asia Pacific

**AU – Australia,** Castle Hill

Tel: +61 (0)2-9634 7777

**CN – China,** Shanghai

Tel: +86 21 2899 5000

**HK – Hong Kong**

Tel: +852 2428 8008

**IN – India,** Mumbai

Tel: +91 22 6513 7081-85

**JP – Japan,** Tokyo

Tel: +81 (0)3 6408 3901

**KR – South Korea,** Seoul

Tel: +82 2 559 0400

**MY – Malaysia,** Shah Alam

Tel: +60 3 7849 0800

**NZ – New Zealand,** Mt Wellington

Tel: +64 9 574 1744

**SG – Singapore**

Tel: +65 6887 6300

**TH – Thailand,** Bangkok

Tel: +662 186 7000-99

**TW – Taiwan,** Taipei

Tel: +886 2 2298 8987

## South America

**AR – Argentina,** Buenos Aires

Tel: +54 3327 44 4129

**BR – Brazil,** Sao Jose dos Campos

Tel: +55 800 727 5374

**CL – Chile,** Santiago

Tel: +56 2 623 1216

**MX – Mexico,** Apodaca

Tel: +52 81 8156 6000

European Product Information Centre

Free phone: 00 800 27 27 5374

(from AT, BE, CH, CZ, DE, DK, EE, ES, FI, FR, IE, IL, IS, IT, LU, MT, NL, NO, PL, PT, RU, SE, SK, UK, ZA)

## Parker Hannifin Ltd.

Tachbrook Park Drive

Tachbrook Park,

Warwick, CV34 6TU

United Kingdom

Tel.: +44 (0) 1926 317 878

Fax: +44 (0) 1926 317 855

parker.uk@parker.com

www.parker.com

